

<b>NORLEG</b>	
Lilleput by	
LE 20720	
10.01.2014	REV. B:02.01.2019

< 900

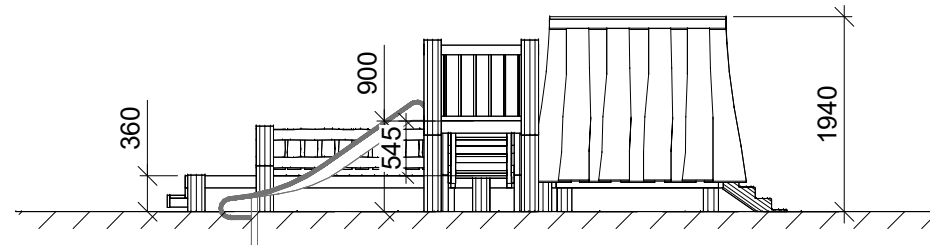

≥ EN 1176

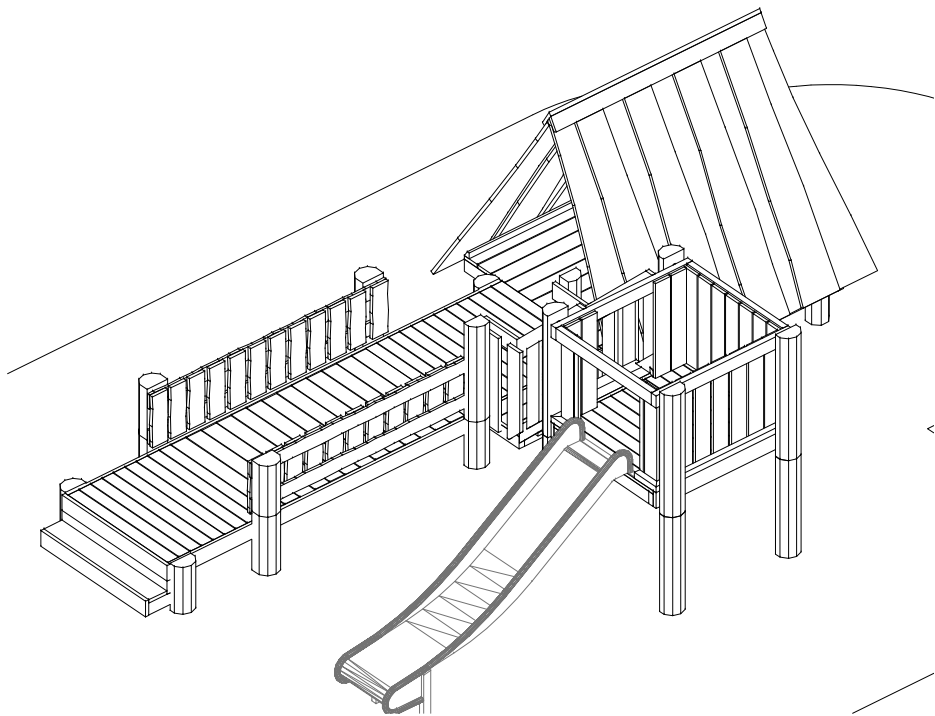

1:75

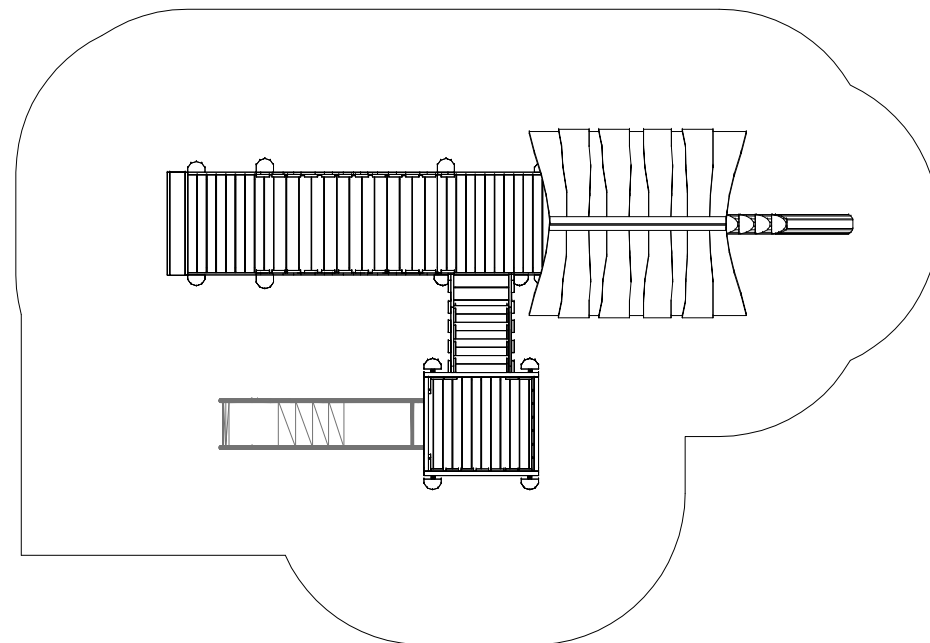

1:75

This drawing is the property of NORLEG and pursuant to current legislation may not be copied, transferred to or used by any third party. Should this drawing be used, a fee of 10% of the assumed contract price will be charged.

# NORLEG - 3D

Lilleput by

LE 20720

10.01.2014

REV. B:02.01.2019

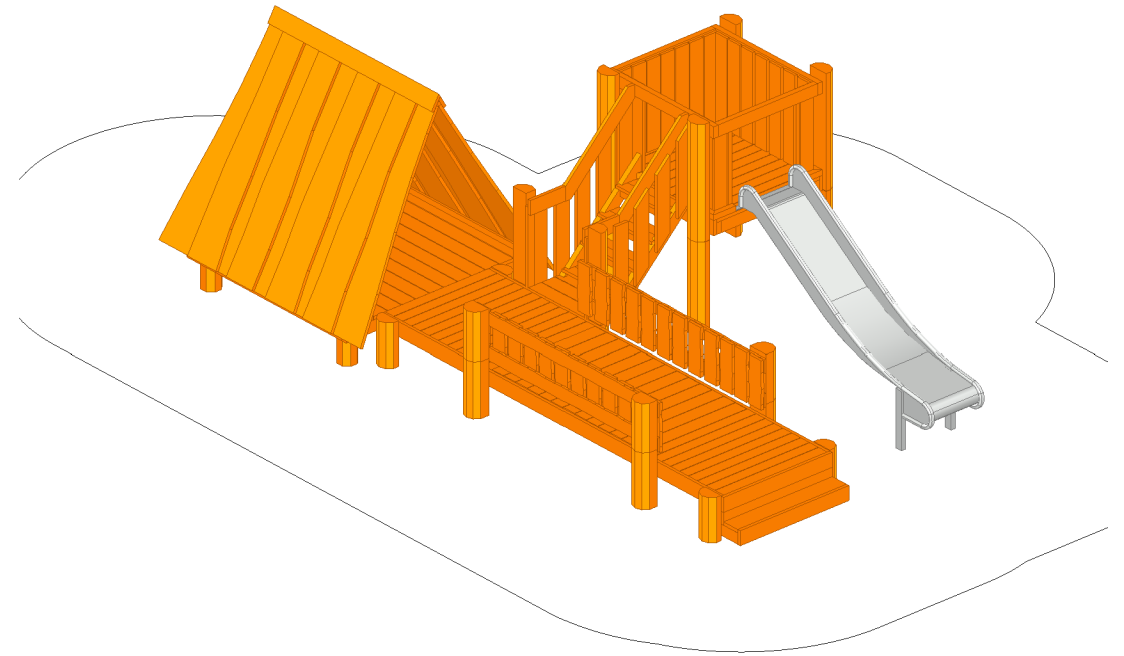
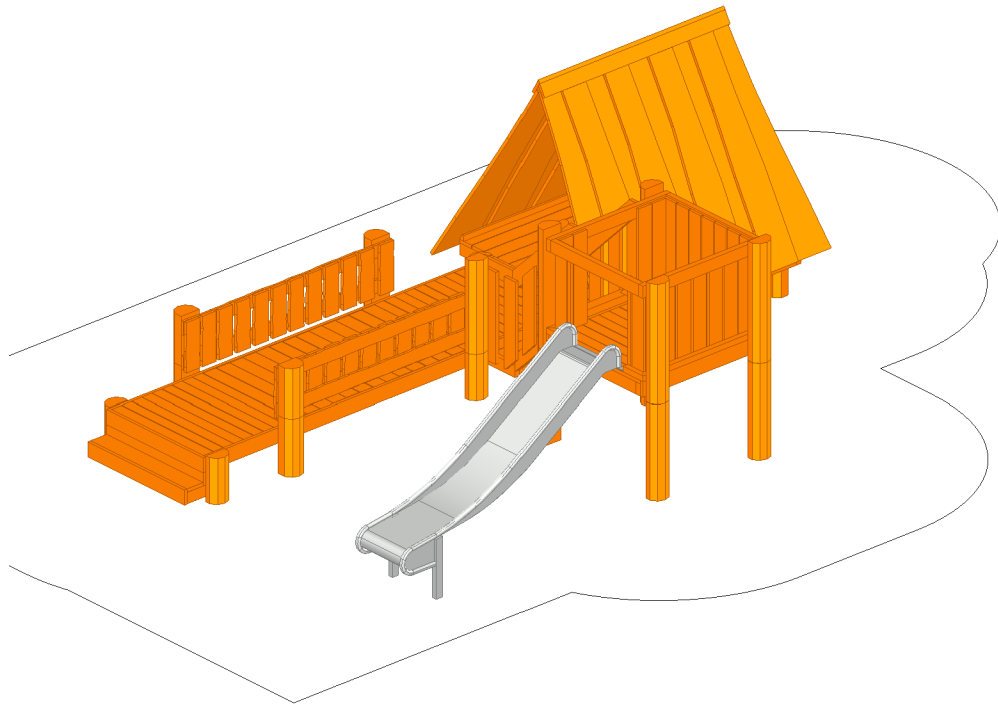

<b>NORLEG</b> - Mont.	
Lilleput by	
LE 20720	
10.01.2014	REV. B:02.01.2019

< 900



≥ EN 1176

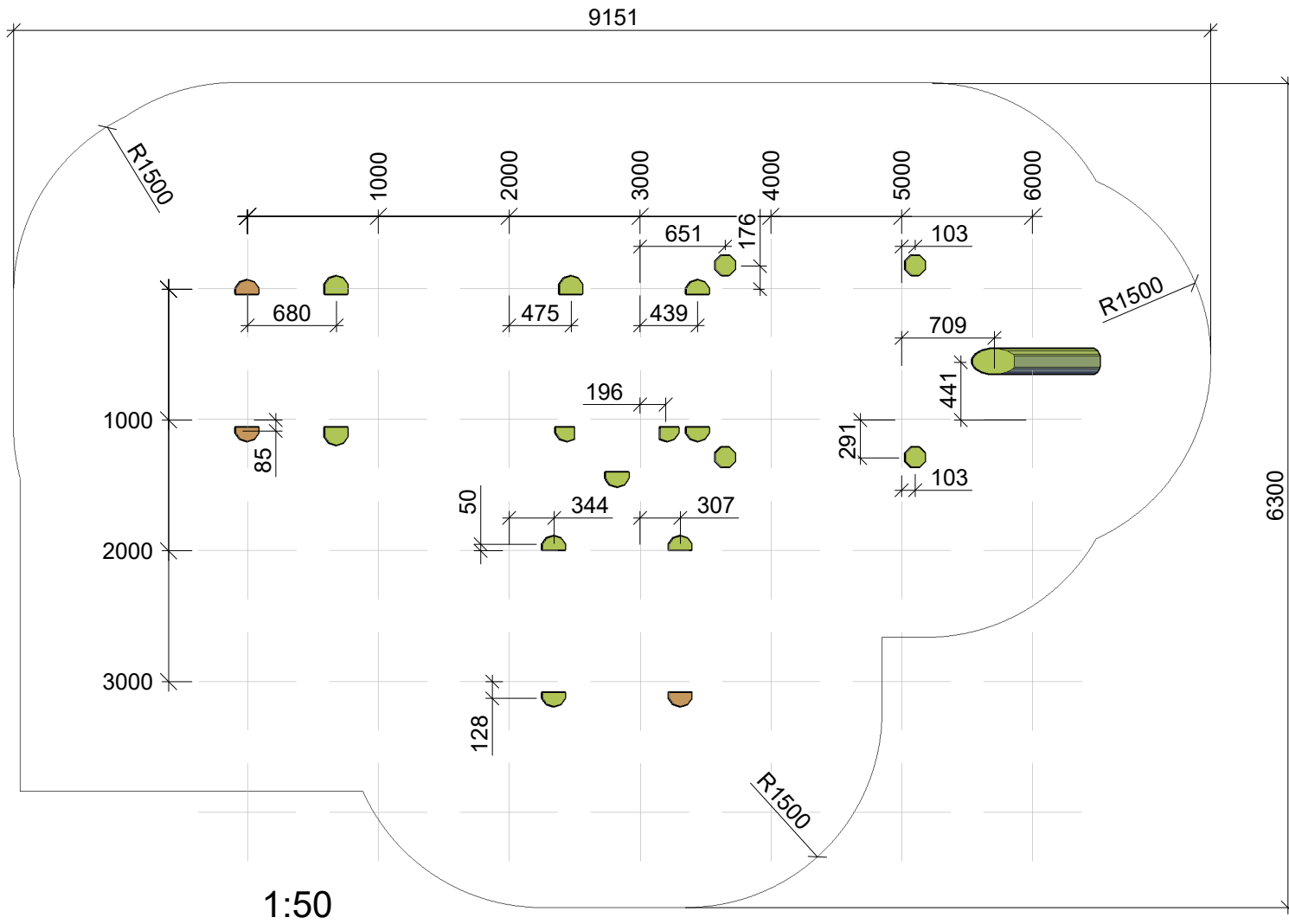

This drawing is the property of NORLEG and pursuant to current legislation may not be copied, transferred to or used by any third party. Should this drawing be used, a fee of 10% of the assumed contract price will be charged.

# NORLEG - Montage

Lilleput by

LE 20720

Tegner

-

Godkendt af

-

10.01.2014

REV. B:02.01.2019

## Parts list

Mrk.	QTY	Part.no
1	2	140-160-1160-k
2	3	140-160-1650-k
3	2	140-160-1900-v
4	2	140-160-1160-k
5	4	140-160-1100
6	1	140-160-1130-k
7	4	160-180-2500-k
8	1	180-200-1500-z-4 trin

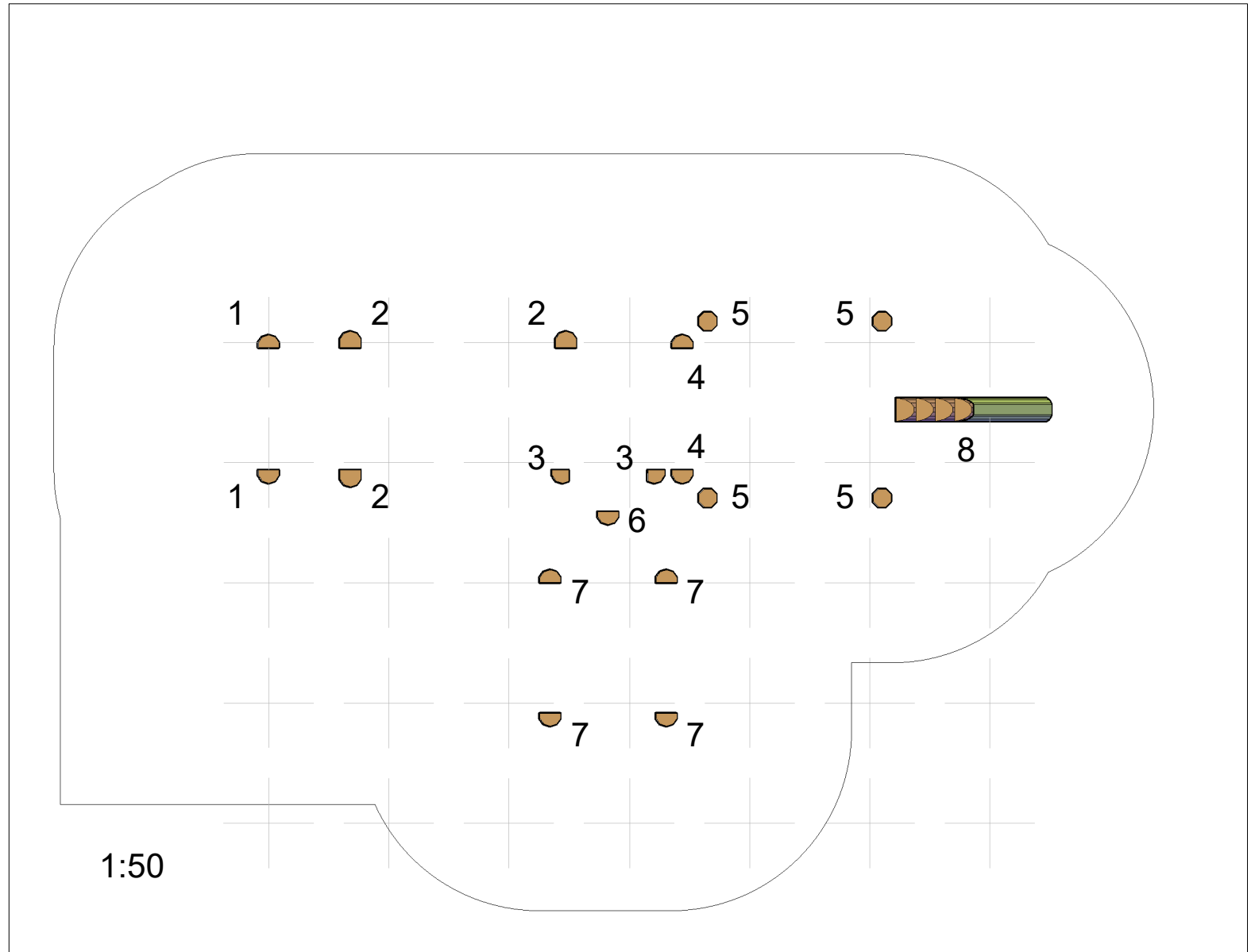

- k = Kantskåret
- d = Dobbeltskåret
- v = Vinkelskåret
- h = Halvskåret
- t = k på 3 sider
- z = Speciel - se detalje
- f = Forboring + montering

Denne tegning er NORLEG's ejendom, og må ifølge gældende lov ikke kopieres, overlades eller udnyttes af 3. mand. Sker dette, skal det påregnes, at der vil blive opkrævet et honorar på 10% af formodet entreprisum.

<b>NORLEG</b> - Mont.	
Lilleput by	
LE 20720	
10.01.2014	REV. B:02.01.2019

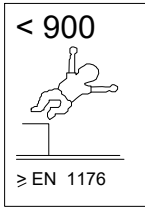

By assembly. Drilling and use of saw must be expected.

Dh = Disk head

Ch = Countersunk head

Mont.p. nr.

19  
24  
52A

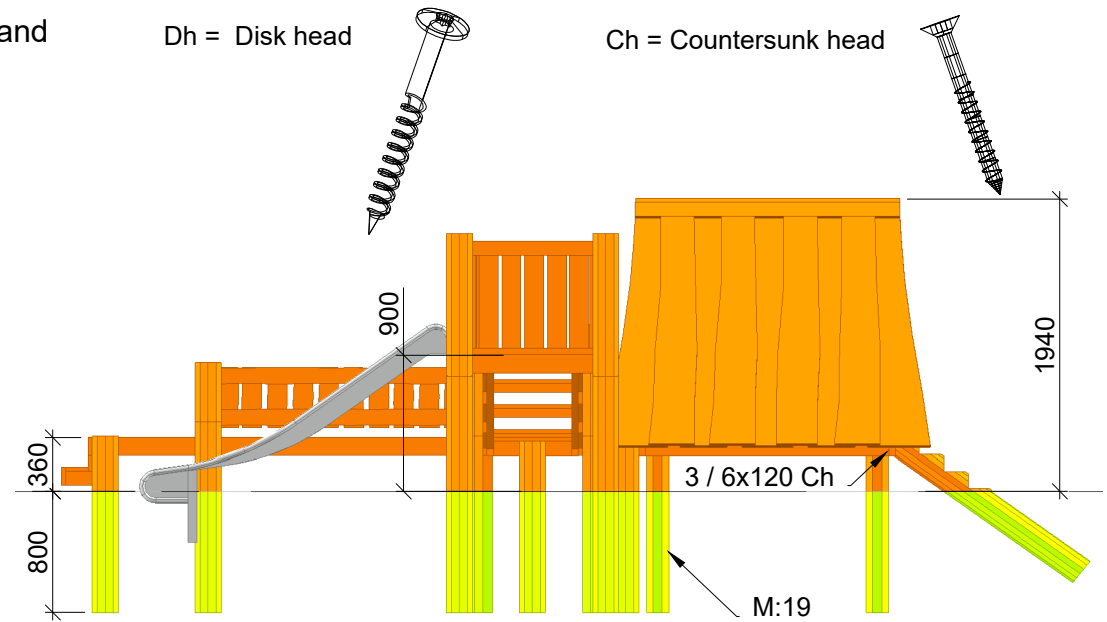

1:50

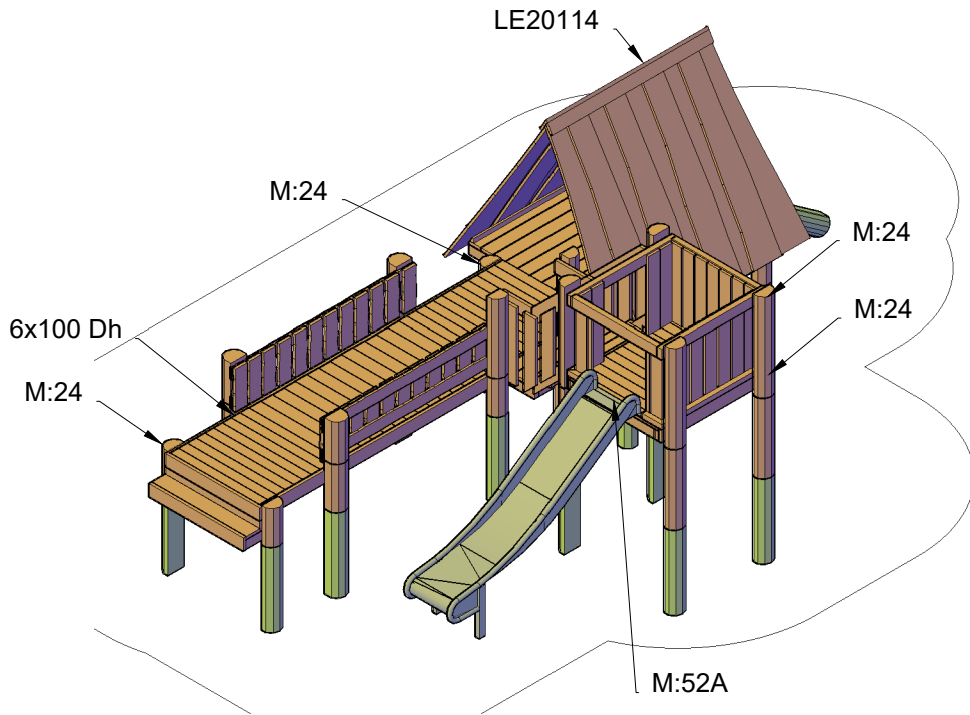

1:50

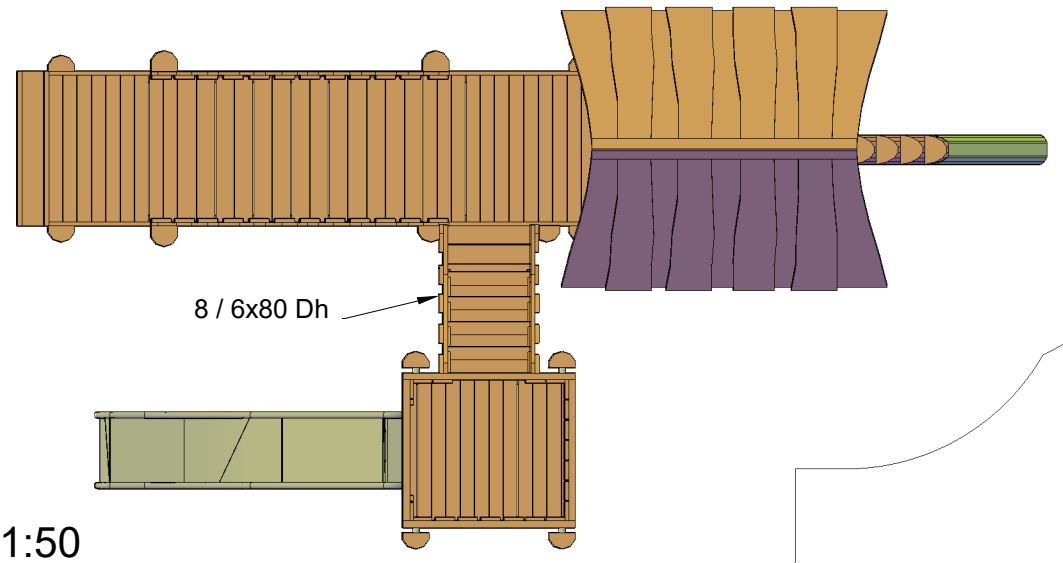

This drawing is the property of NORLEG and pursuant to current legislation may not be copied, transferred to or used by any third party. Should this drawing be used, a fee of 10% of the assumed contract price will be charged.