

PL	INSTRUKCJA MONTAŻU	Nazwa	Zestaw Milo 2	Nr kat.	6502
ENG	ASSEMBLY INSTRUCTIONS	Product		Cat. no.	
DEU	MONTAGEANLEITUNG	Name		Art.-Nr.	

## 6502



Wiek użytkowników Age of users Altersgruppe	Ilość użytkowników Number of users Anzahl der Benutzer	Przeznaczenie urządzenia Purpose of device Bestimmung des Spielgerätes	Zgodność z normą In accordance with the standard Geltende Norm
1-6	8	do zabawy na zewnątrz for outdoor playing zum draußen Spielen	PN-EN 1176-1:2017
NOVUM Sp. z o.o. ul. Gnieźnieńska 2a, 12-100 Szczytno		e-mail: kontakt@novum4kids.pl e-mail: export@novum4kids.com	www.novum4kids.pl www.novum4kids.com

**UWAGA / WARNING / ACHTUNG:**

**PL** Jeżeli w zestawie występuje zjeżdżalnia, zestaw należy posadzić w taki sposób, aby ślizg zjeżdżałni znajdował się od strony północnej, czyli od strony nienasłonecznionej, aby zapobiegać nadmiernemu nagrzewaniu się ślizgu.

**ENG** If there is a slide in the set, it should be installed from the north, poorly sunny side to avoid possible hazards (burns) through direct skin contact.

**DEU** Wenn eine Spielplatzanlage eine Rutsche enthält, sollte diese Anlage so platziert werden, dass die Rutsche sich auf der Nordseite befindet, dh. auf der schattigen Seite, um übermäßige Erwärmung der Rutschbahn zu vermeiden.

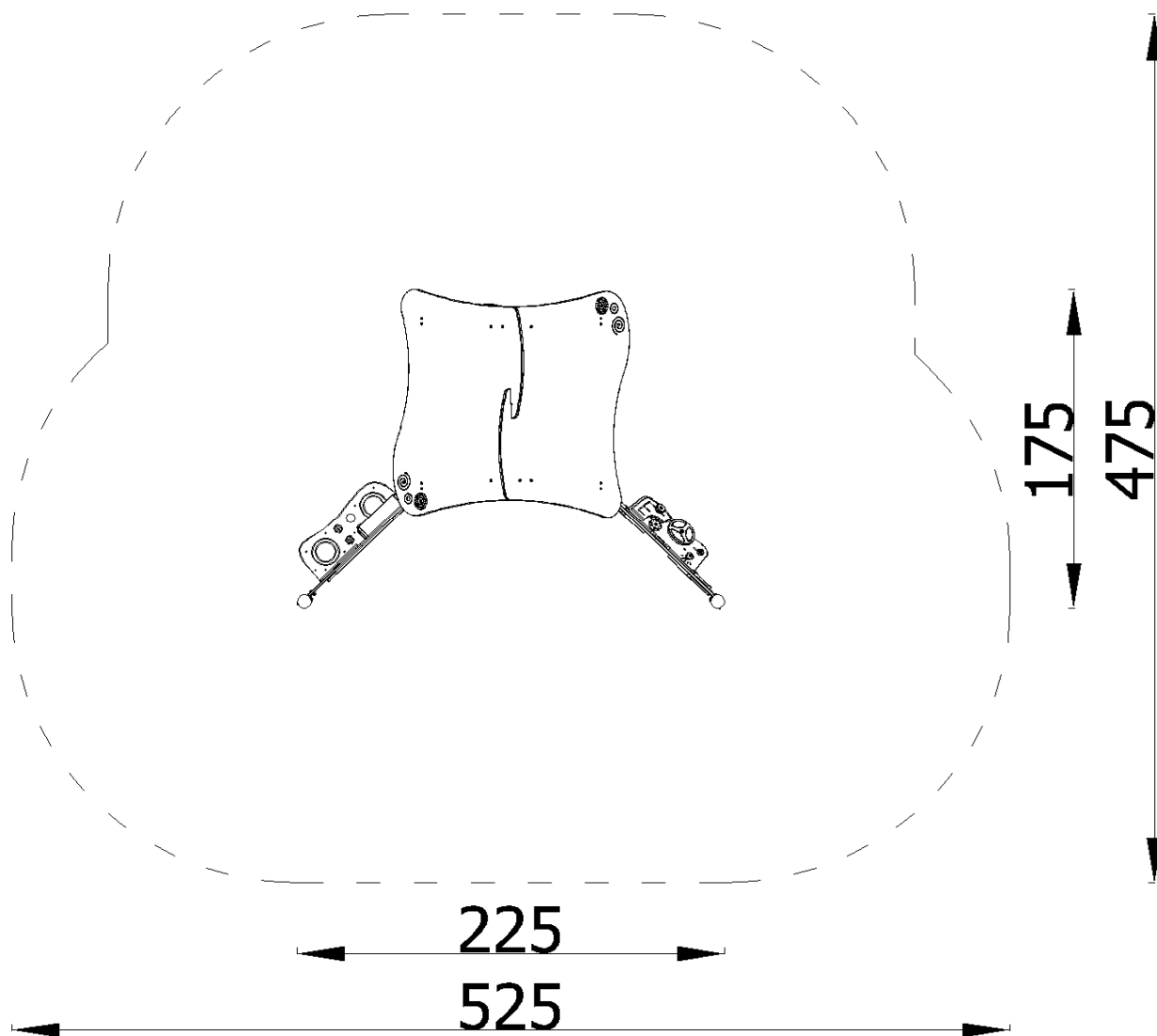

Montaż zgodnie z planem zagospodarowania terenu.  
 Installation in accordance with the land development plan.  
 Montage gemäß dem Flächennutzungsplan

Bezpieczna nawierzchnia / Safe surface / Safe Oberfläche

Strefa Zone Zone	Max. wysokość upadku Max. fall height Max. Fallhöhe	Pole powierzchni Surface area Fläche	Obwód strefy bezpiecz. Perimeter security zone Umkreis der Fallschutzfläche
A	0,00 m	21,00 m <sup>2</sup>	17,00 m
B	-	-	
C	-	-	

Nawierzchnia / Safe surface / Fallschutzbelag

6502

	Materiał Material Material		Min. wysokość warstwy Min. layer thicknesses Min. Schichtöhe
$h < 0,6 \text{ m}$	Beton / Concrete / Beton Nawierzchnia bitumiczna / Bituminous surfacing / Bituminöse Oberfläche		
$h \leq 1 \text{ m}$	Gleba / Topsoil / Boden Darń / Turf / Grasnarbe		
$h \leq 2 \text{ m}$	Kora / Bark / Borke	20÷80 mm	300
	Wióry / Wood chips / Holzhackschnitzel	5÷30 mm	
	Piasek / Sand / Sand Żwir / Gravel / Kies	0,25÷8 mm	
$h \leq 3 \text{ m}$	Kora / Bark / Borke	20÷80 mm	400
	Wióry / Wood chips / Holzhackschnitzel	5÷30 mm	
	Piasek / Sand / Sand Żwir / Gravel / Kies	0,25÷8 mm	
$h \leq 3 \text{ m}$	Nawierzchnia syntetyczna / Synthetic granulates / Synthetische Oberfläche		wg danych producenta acc. to the manufacturer's data nach Angaben des Herstellers

Posadowienie / Foundation / Gründung

6502

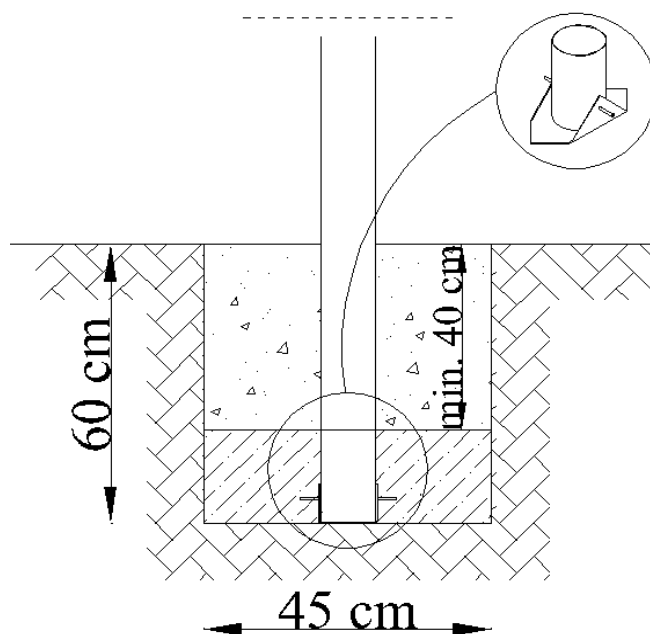

Beton / Concrete / Beton: **C16/20** - **0,19 m<sup>3</sup>**

W celu kontroli fundamentów należy usunąć nawierzchnię bezpieczną / piasek / żwir etc.  
 In order to control the foundations, remove the safe surface (sand, gravel, etc.)  
 Um die Fundamente zu überprüfen, entfernen Sie den Fallschutzbelag: Sand/ Kies etc.

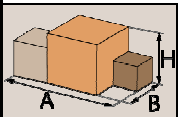
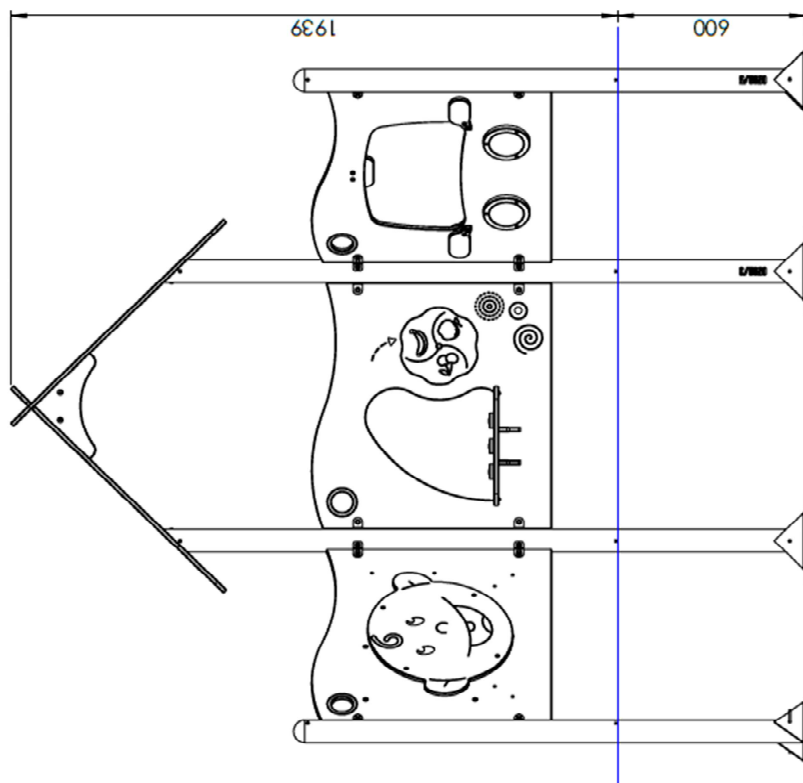
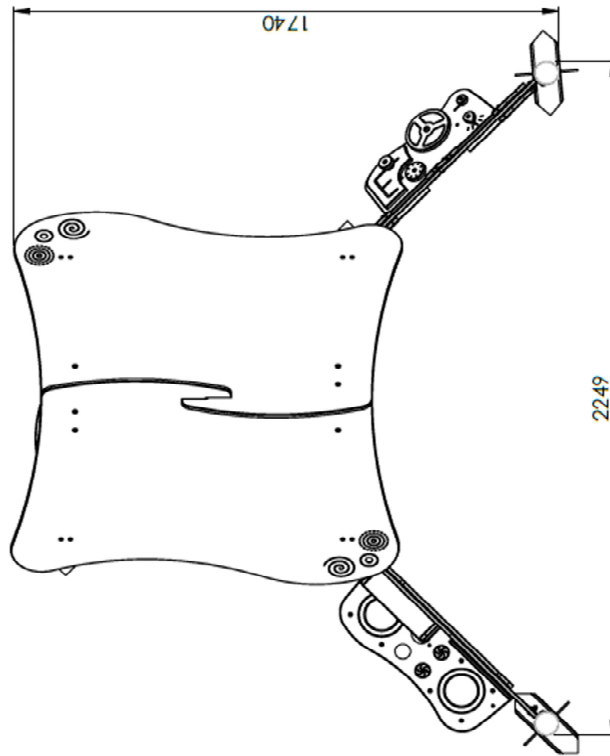

2,25x1,75x1,94  
(AxBxH) [m]



137 kg

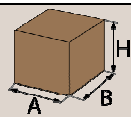

0,2x0,2x2,1  
(AxBxH) [m]



30 kg

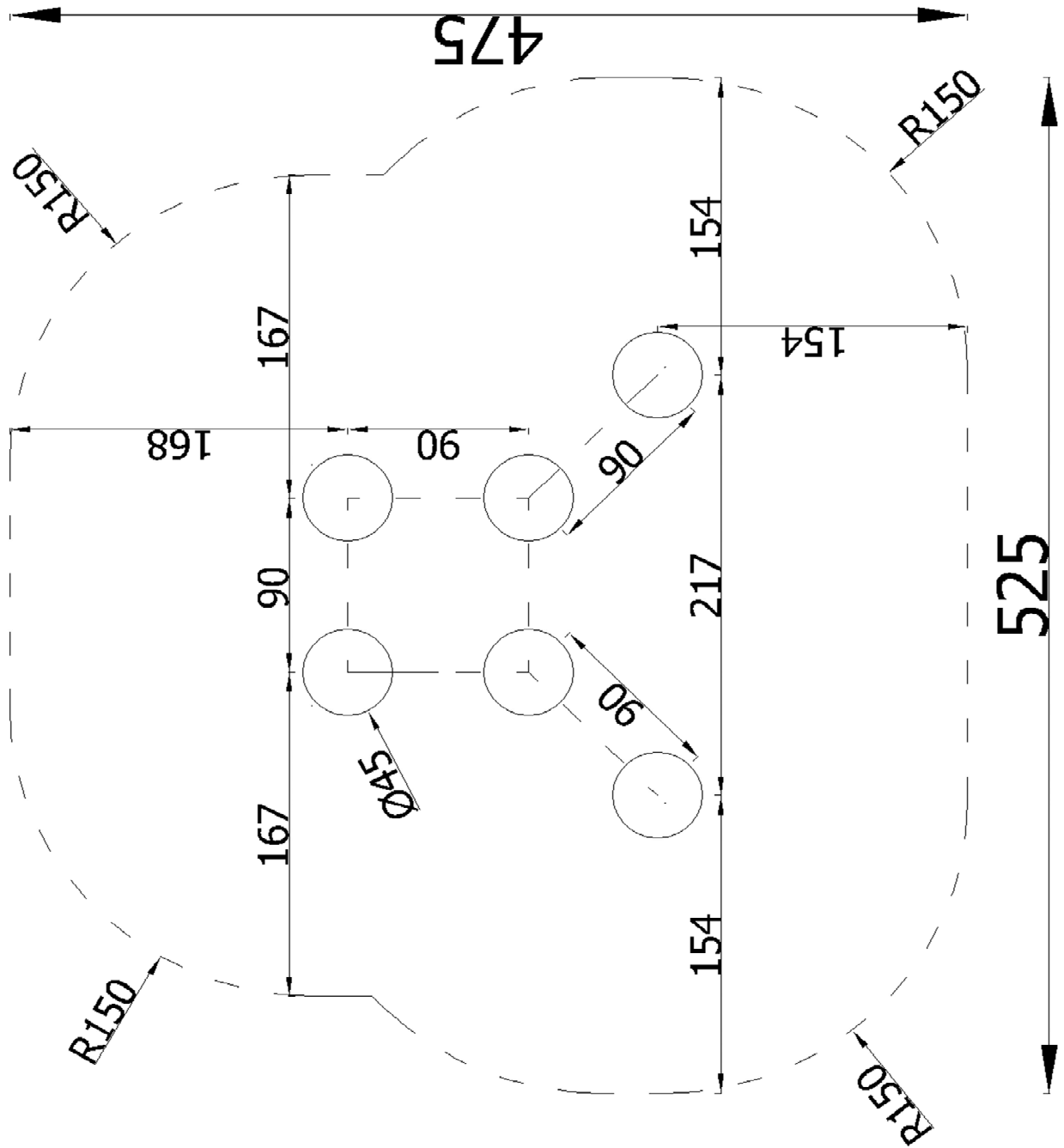

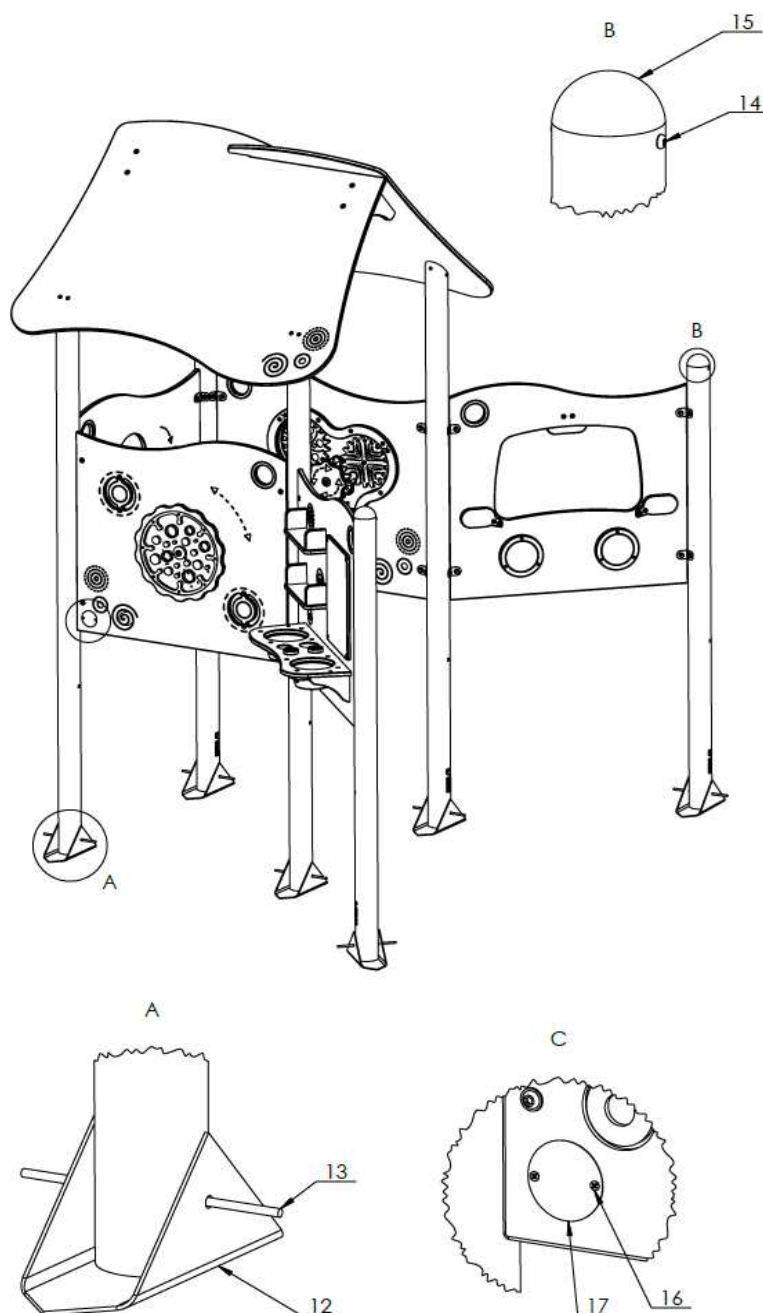



Części zamienne dostępne u producenta.  
Stosować klej do gwintów w połączeniach śrubowych.

Spare parts available from the manufacturer.  
Use thread glue in screw connections.

Ersatzteile beim Hersteller erhältlich.  
Gewindekleber für Schraubverbindungen verwenden.

17	8918_006	1
16	DIN7997_3,5x12_A2	2
15	8912_118	2
14	8905_502_A2	4
13	8850_002	6
12	B_8802_026	6
11	69501	1
10	69412	1
9	69408	1
8	69407	1
7	69405	1
6	69403	1
5	R_6502_005	2
4	R_6502_004	1
3	R_6502_003	1
2	R_6502_002	1
1	R_6502_001	1
Lp.	Nr części	Ilość
No.	Art. Nr.	Quantity Anzahl
	Part No.	Teile-Nr

															
								5 m	30 m						
															
2,5 m				60 cm	100 cm										
															
				7 mm								13 mm	17 mm	19 mm	24 mm
															
13 mm	17 mm	19 mm	24 mm	4 mm	5 mm	6 mm	8 mm	T40				T45			
															

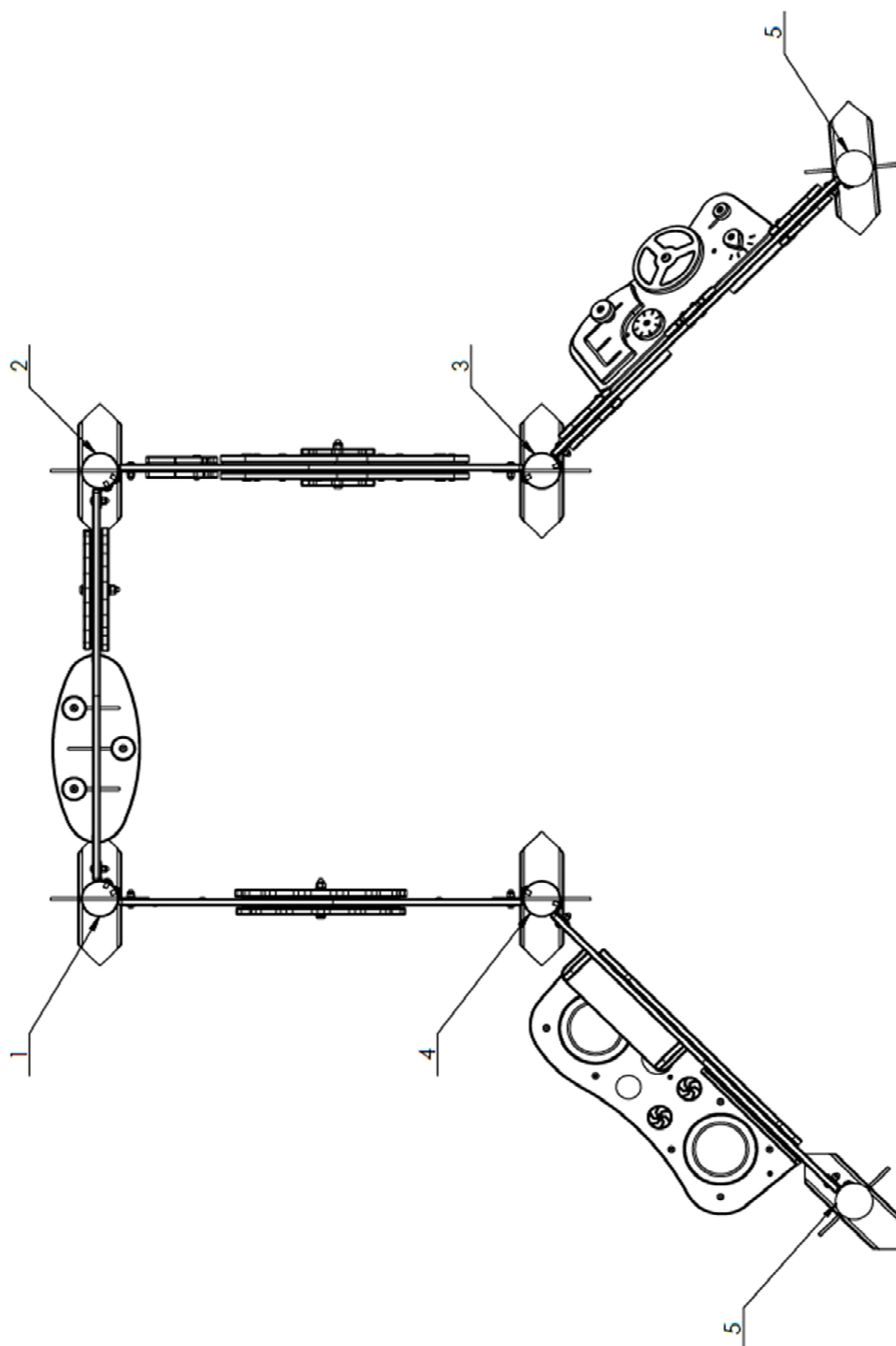



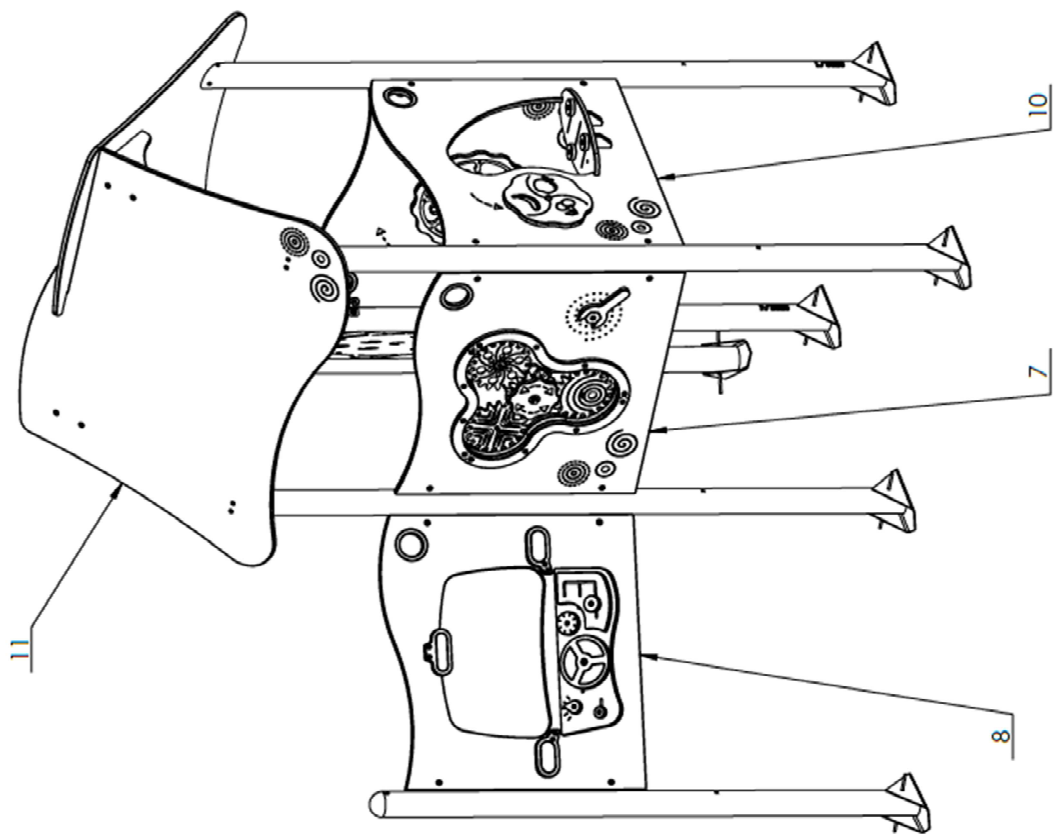
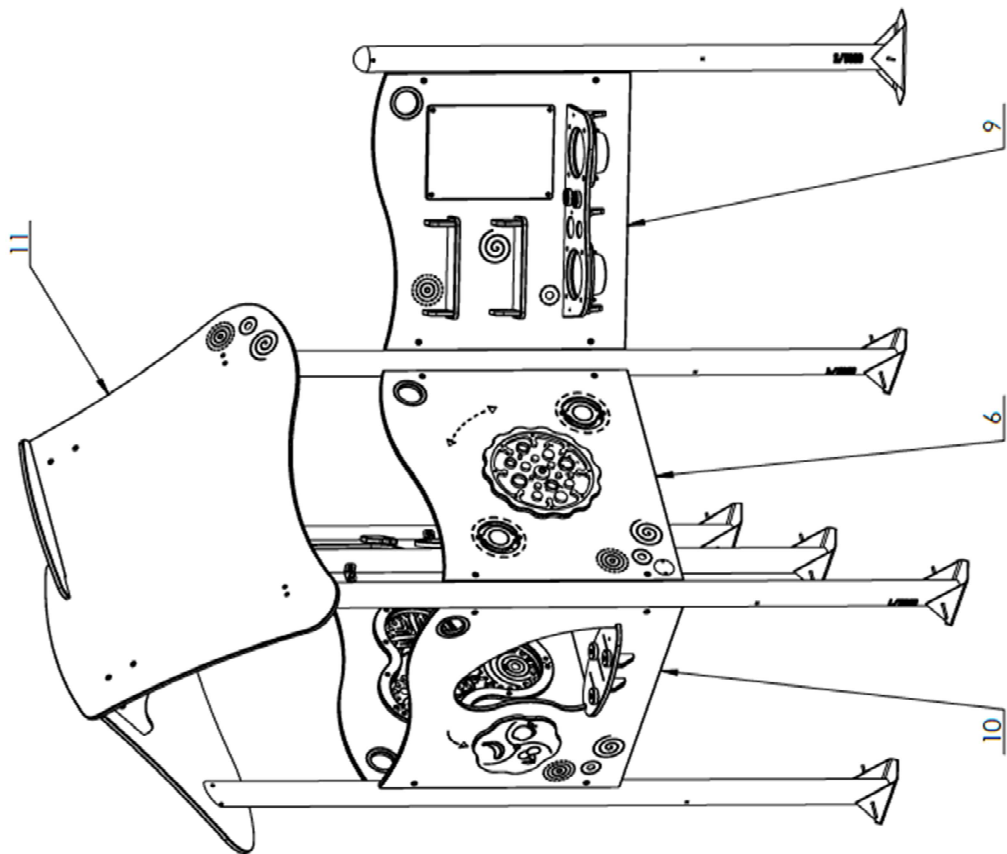

ISO7089_8_A2	4
DIN986_M8_A2	4
ISO7380_2_M8x16_A2	4
ISO7380_2_M8x30_A2	4
B_69000_002	4
69403_003	1
Drawing/Norm	Quantity

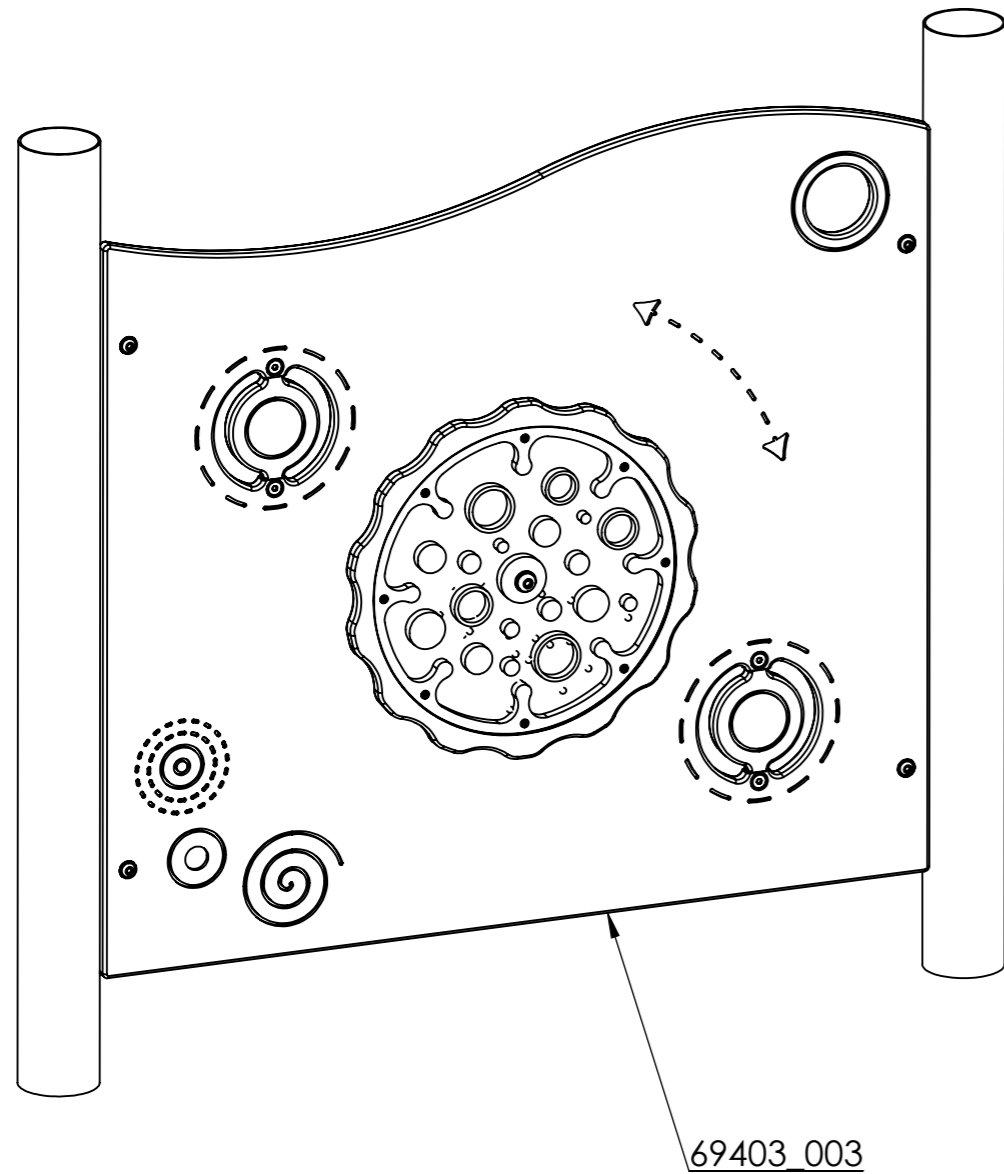

ISO7380\_2\_M8x30\_A2

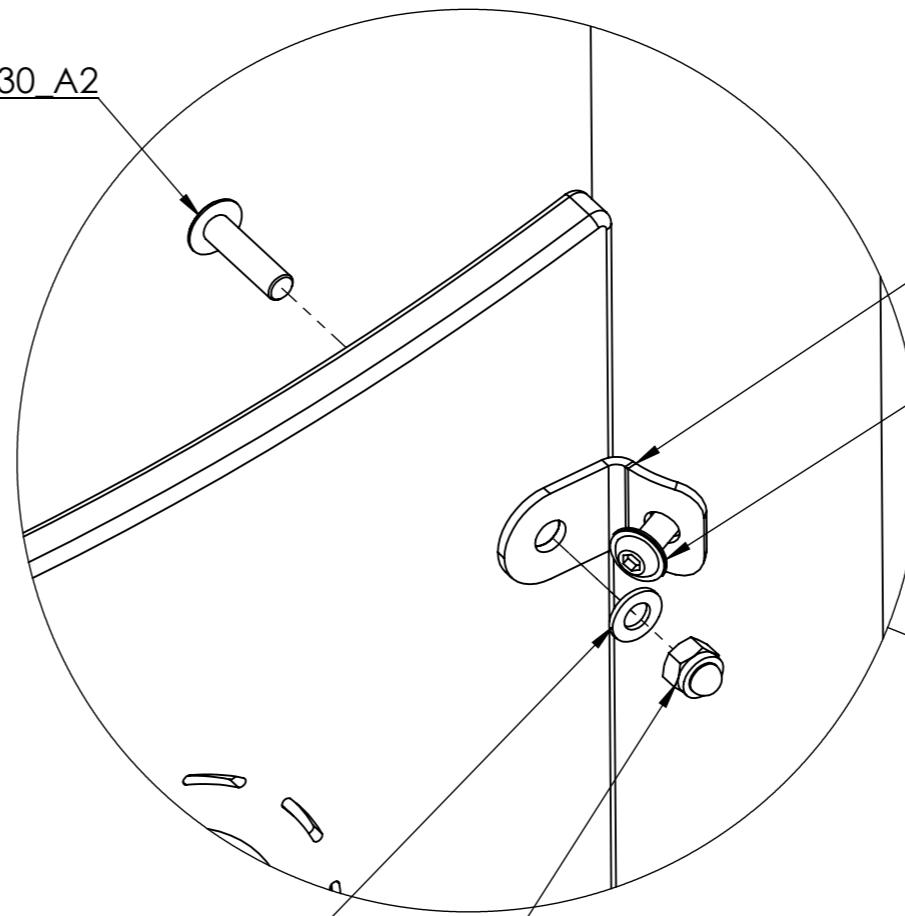

B\_69000\_002

ISO7380\_2\_M8x16\_A2

ISO7089\_8\_A2

DIN986\_M8\_A2

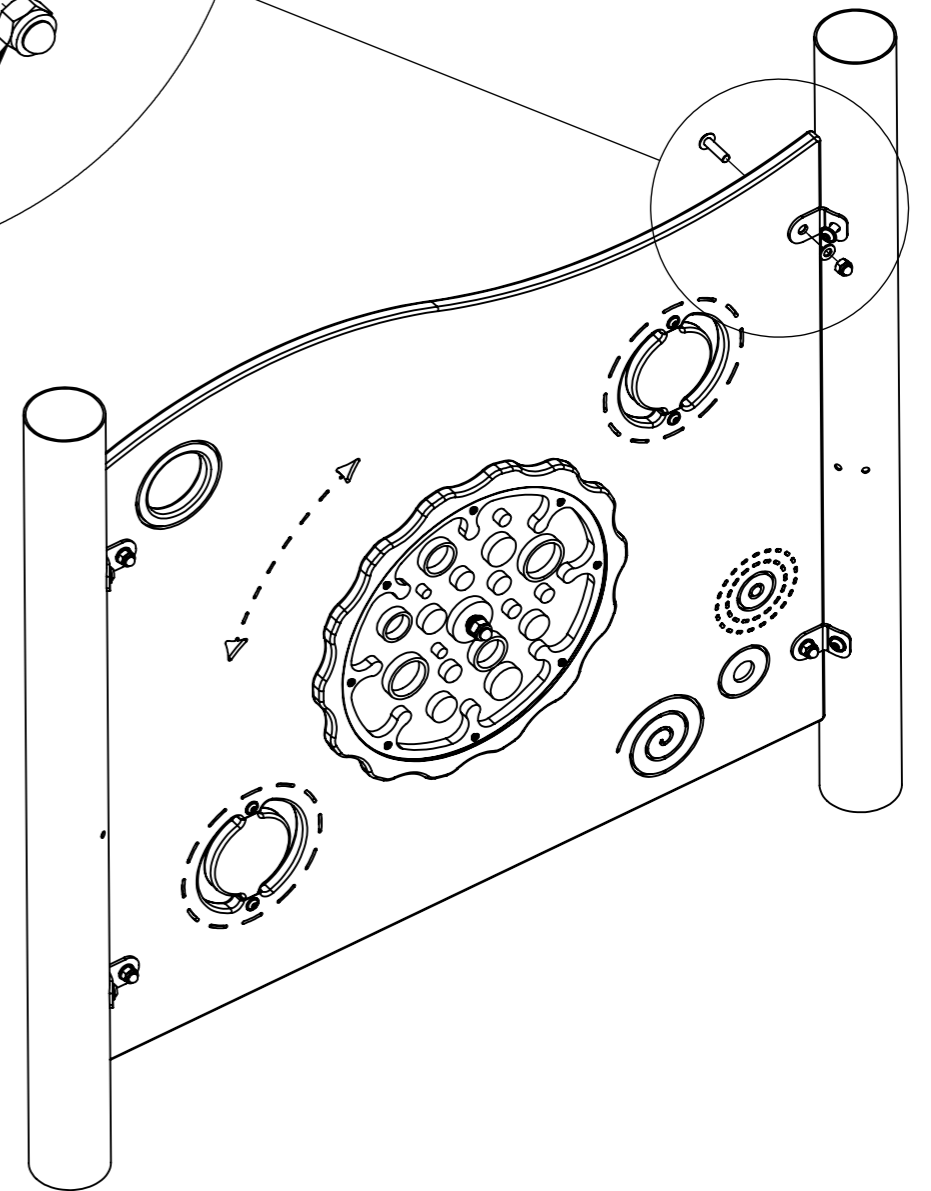

ISO7089_8_A2	4
DIN986_M8_A2	4
ISO7380_2_M8x16_A2	4
ISO7380_2_M8x30_A2	4
B_69000_002	4
69405_001	1
Drawing/Norm	Quantity

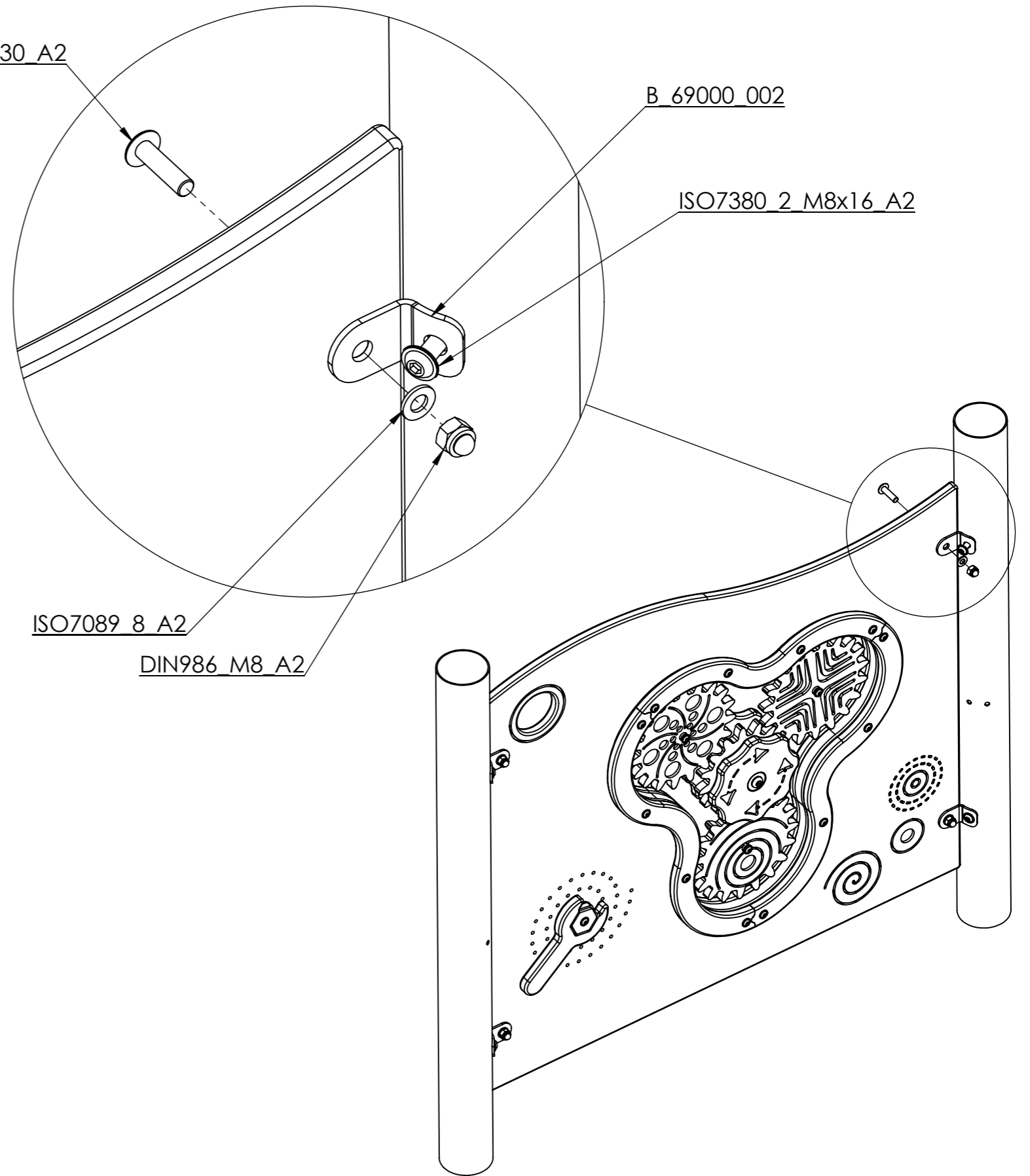
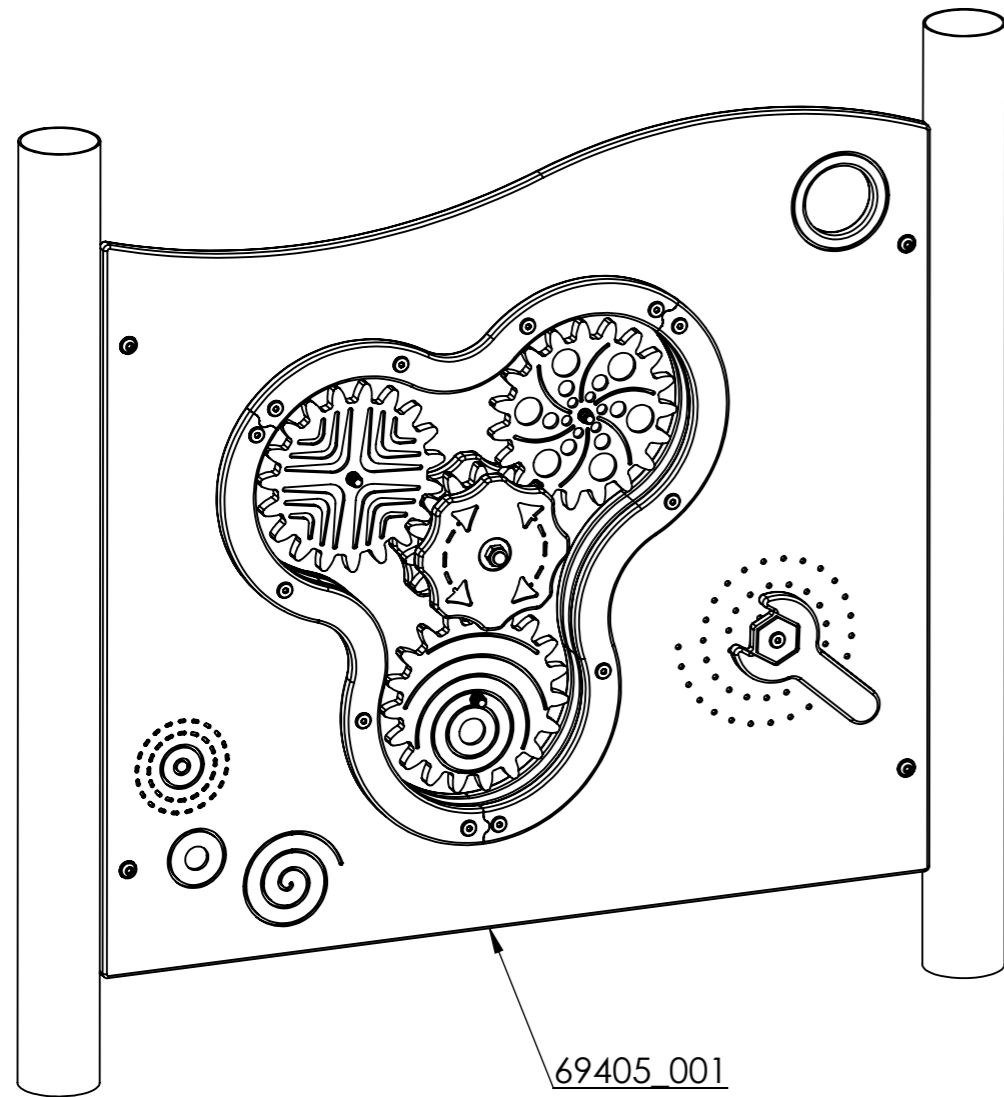

ISO7089_8_A2	4
DIN986_M8_A2	4
ISO7380_2_M8x16_A2	4
ISO7380_2_M8x30_A2	4
B_69000_002	4
69407_002	1
Drawing/Norm	Quantity

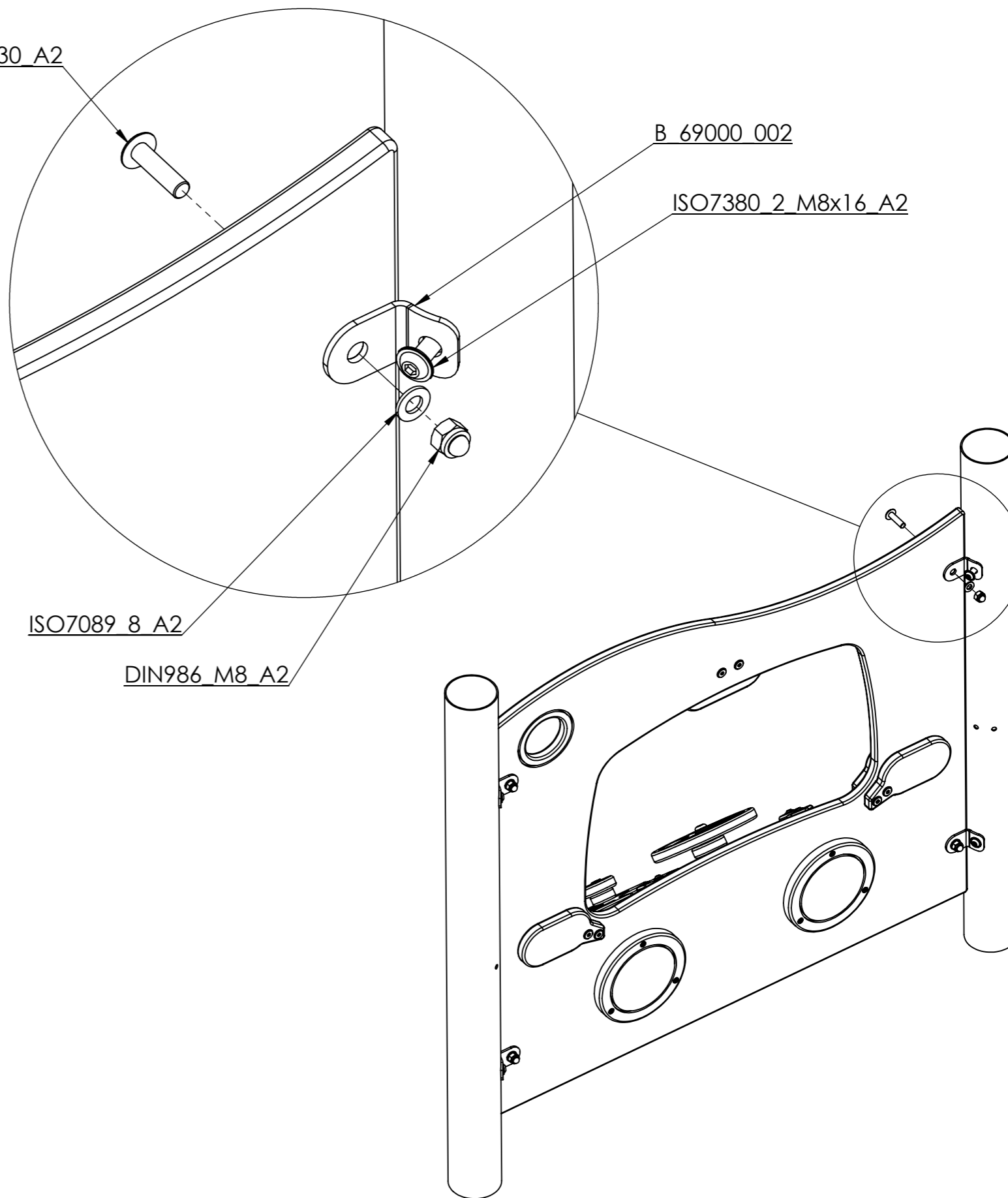
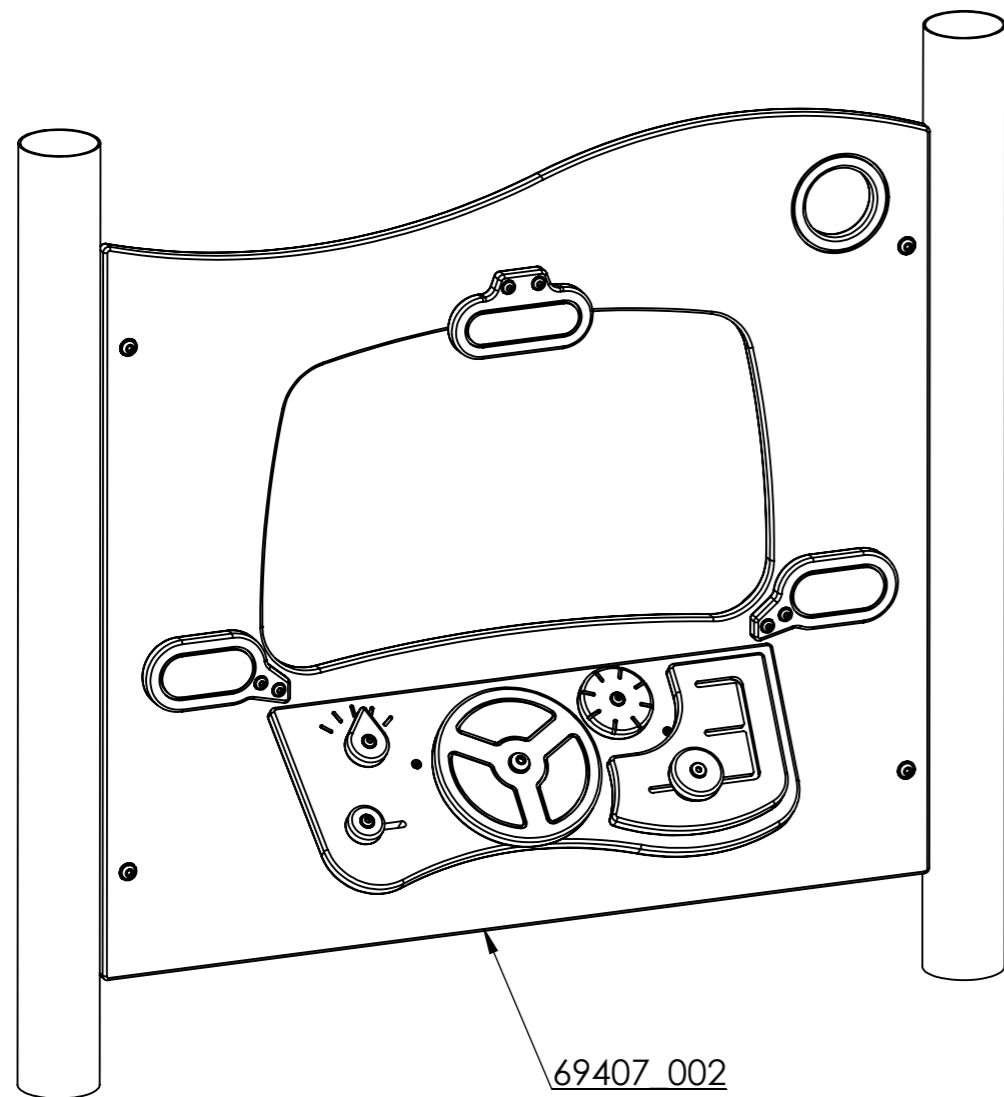

ISO7089_8_A2	4
DIN986_M8_A2	4
ISO7380_2_M8x16_A2	4
ISO7380_2_M8x30_A2	4
B_69000_002	4
69408_002	1
Drawing/Norm	Quantity

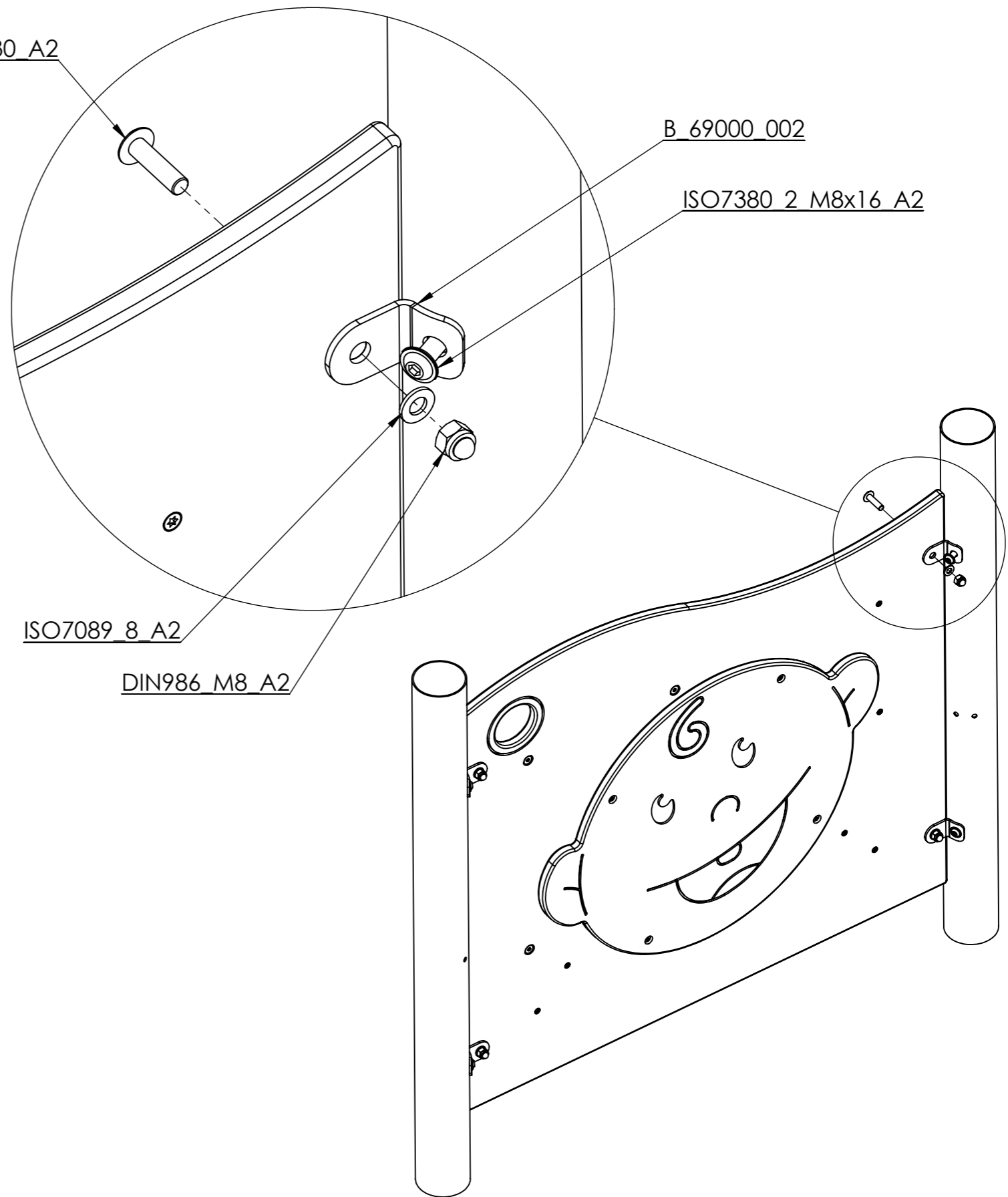
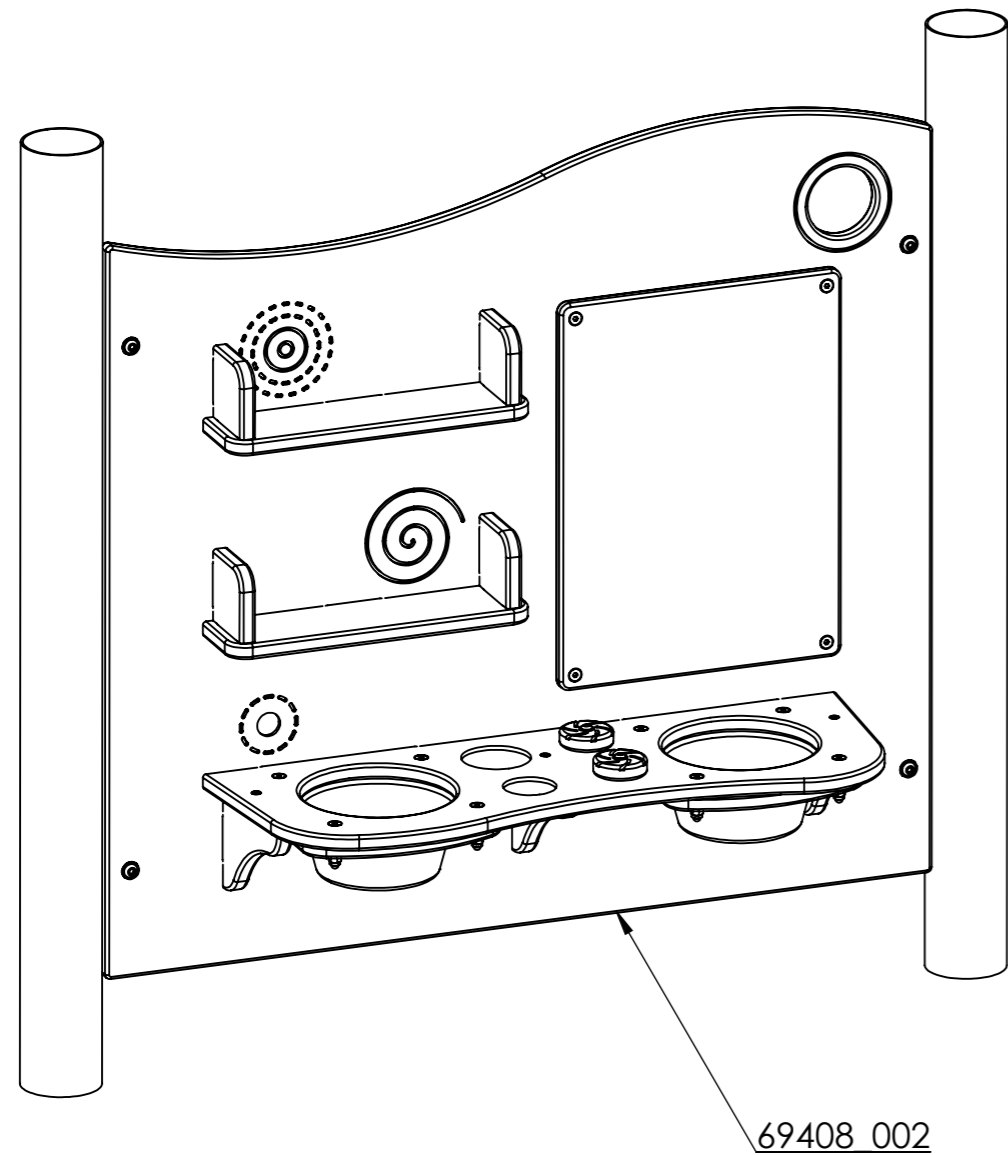

ISO7089_8_A2	4
DIN986_M8_A2	4
ISO7380_2_M8x16_A2	4
ISO7380_2_M8x30_A2	4
B_69000_002	4
69412_001	1
Drawing/Norm	Quantity

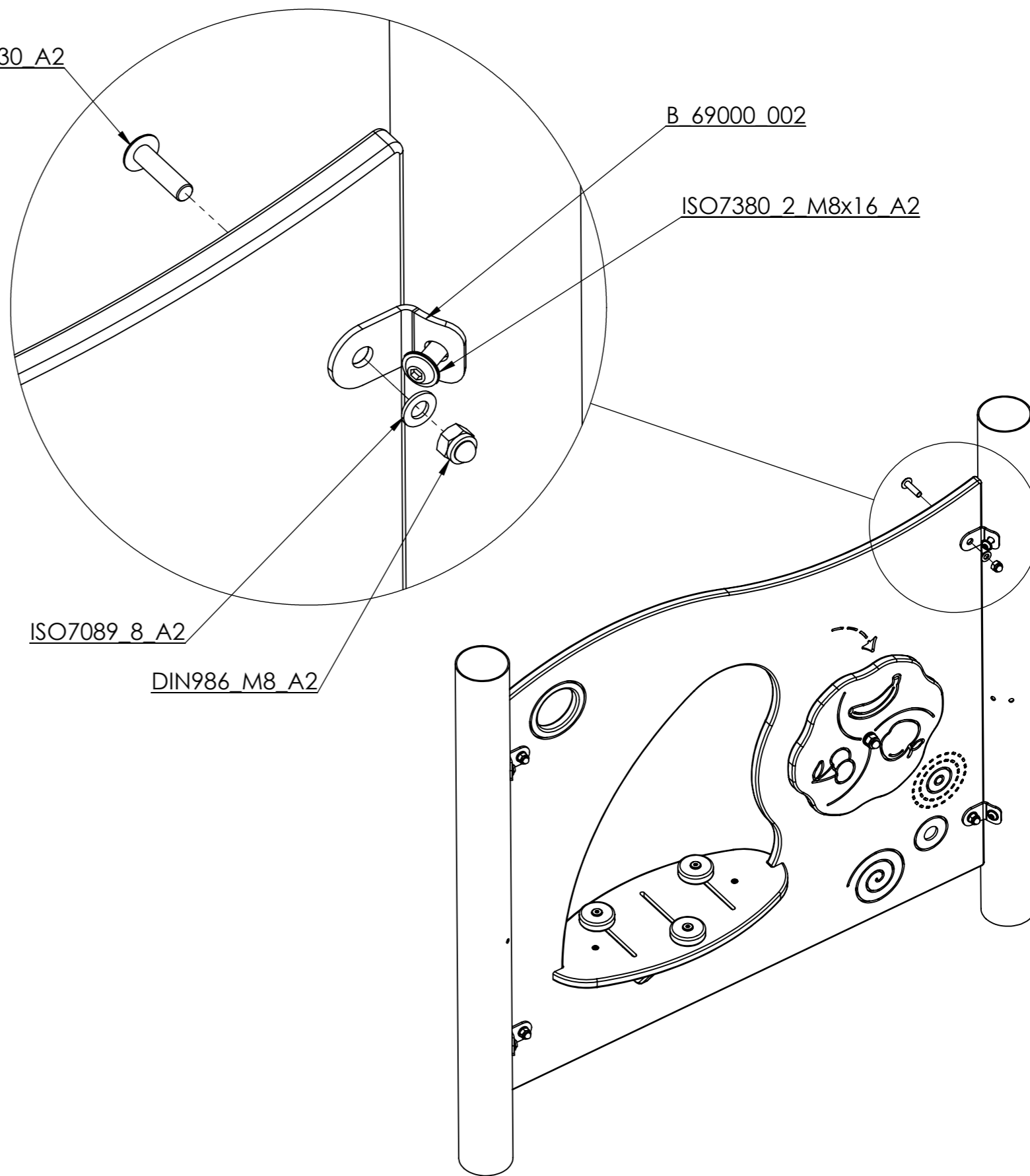
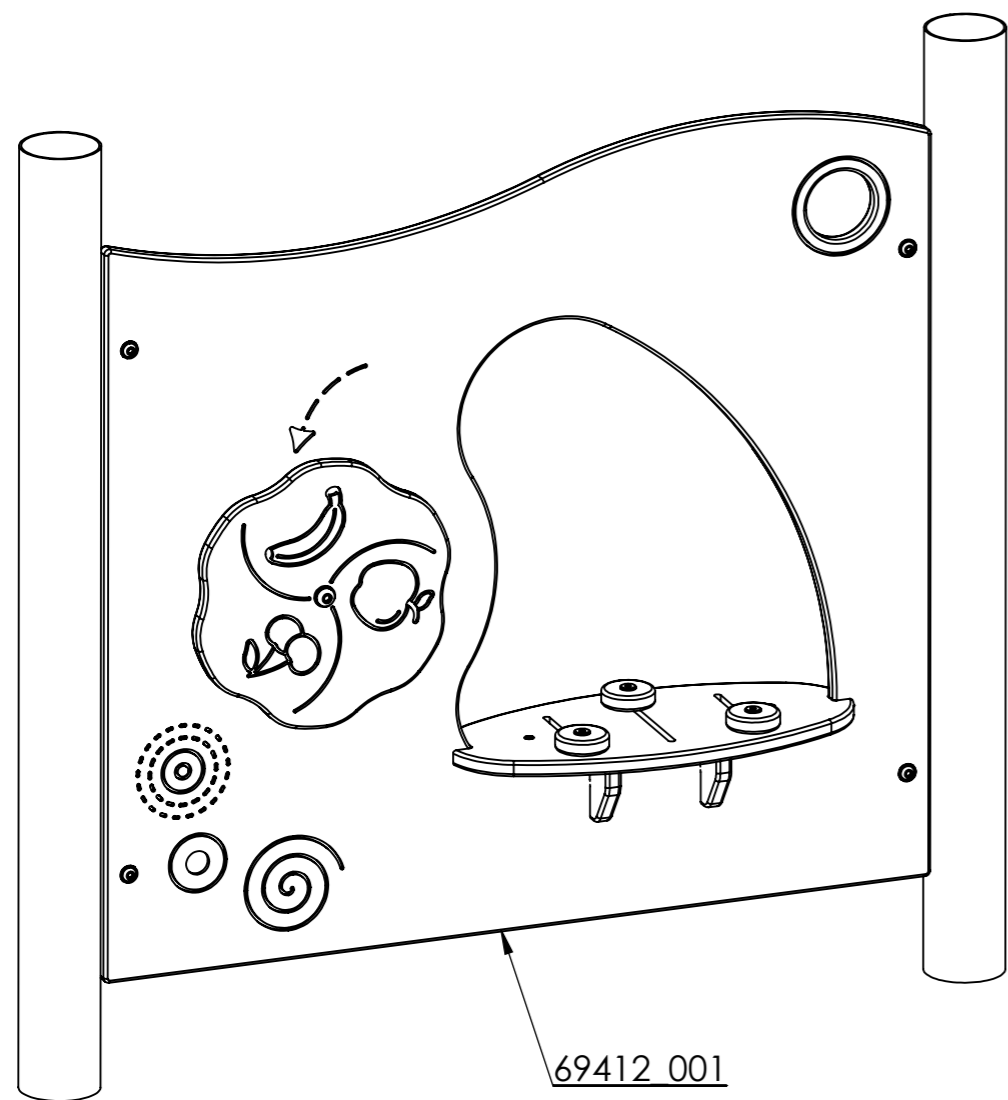

8905_502_A2	12
ISO7089_8_A2	12
DIN986_M8_A2	12
DIN7991_M8x30_A2	12
B_69501_001	2
E_69501_002	2
69501_001	2
Drawing/Norm number	Quantity

